

PARK / NEUTRAL Module 6L80 - 6L90



- Pink** Wire to switched 12volts
- Black** Wire to ground
- BROWN** Wire to GM CAN + High (splice in)
- TAN** Wire to GM CAN - Low. (splice in)
- VIOLET** 12 Volts when in P/N (10 Amps MAX)

OPERATION:

Once the unit is wired in and powered up it will monitor the CAN message from the transmission watching for the Park and Neutral position.

When the module receives a *PARK* or *NEUTRAL* message from the TCM it will send 12 volts out on the VIOLET wire (pin 87).

Pin 87 VIOLET wire has a max output of **10 Amps**. If you are running more than 10 amps we recommend running them from a separate relay and using our output to turn on the relay.

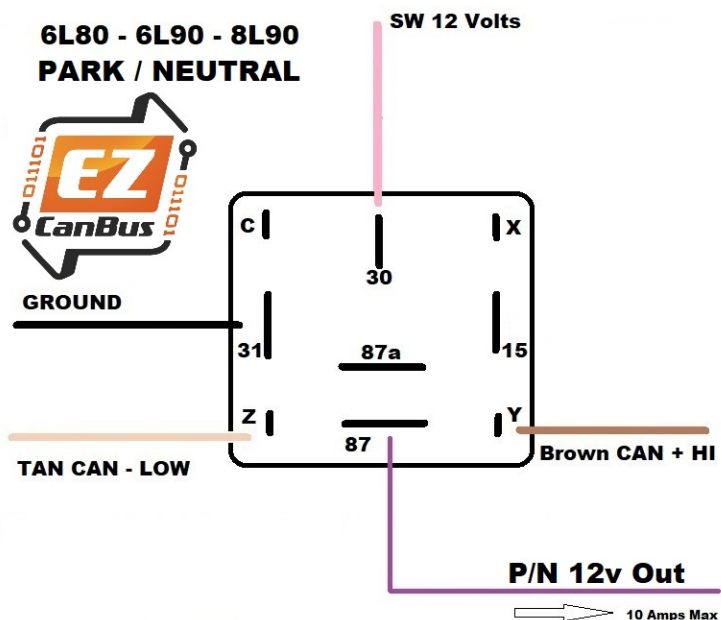

GM E38 ECU

