

6L80-90 TAP SHIFT REVERSE LAMP

NEGATIVE CONTROL



Pink	Wire to switched 12volts
Black	Wire to ground
BROWN	Wire to GM CAN + High
TAN	Wire to GM CAN - Low
WHITE/ BLUE	TAP SHIFT SWITCH UP
WHITE/BLACK	TAP SHIFT SWITCH DOWN
VIOLET	Reverse Lamp Output

OPERATION:

Once the unit is wired in and powered up it will send a CANBUS message to the transmission indicating one of three TAP shift request.

If both TAP inputs are “open” it will send a (no request) message

If the TAP UP input has GROUND applied it will send a (TAP UP) message

If the TAP DOWN input has GROUND applied it will send a (TAP DOWN) message

FYI: if you GROUND both inputs it will send a (no request) message

The TAP switch you use should be a momentary type switch. It should trigger the input only when you have it activated and then return to an open state once you release the button.

REVERSE LAMP:

When the transmission is in reverse there will be 12 volts on the VIOLET wire.

This wire can power your reverse lamps (10 amps max) or power a relay for your reverse lights.

TAP-REVERSE (NEGATIVE)

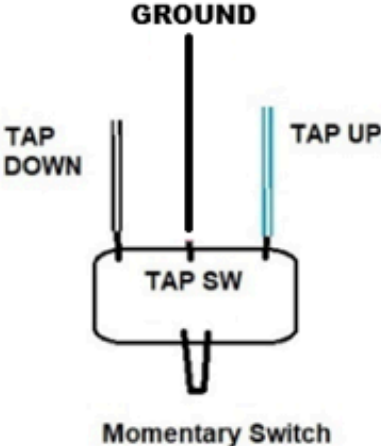
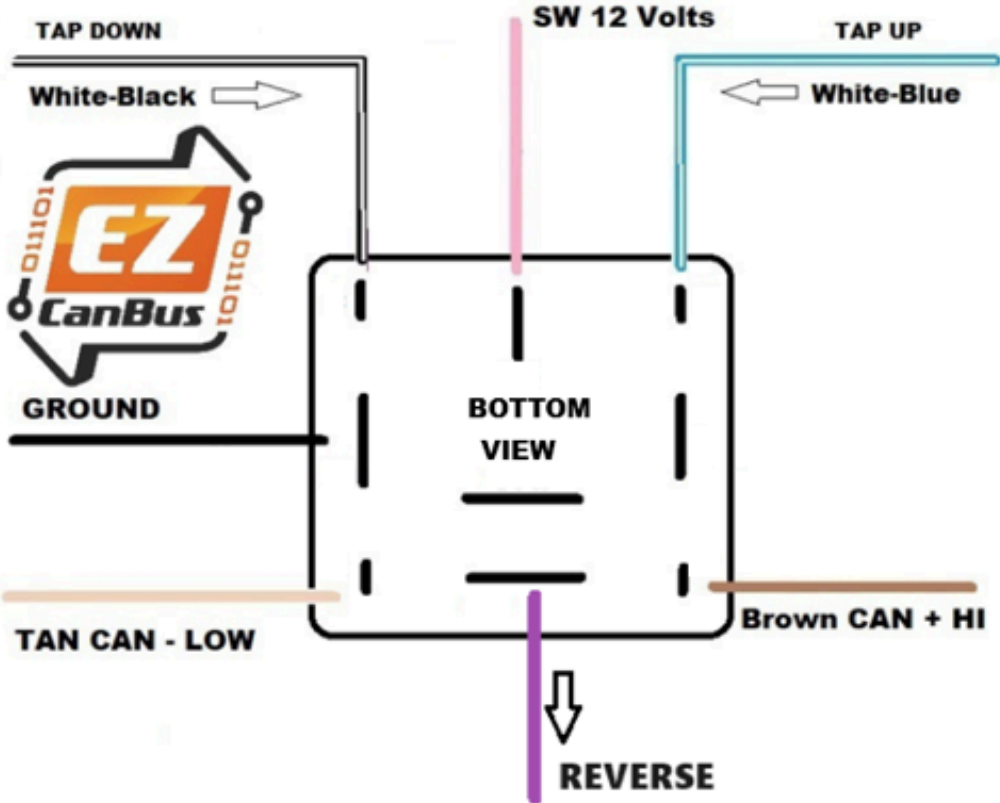

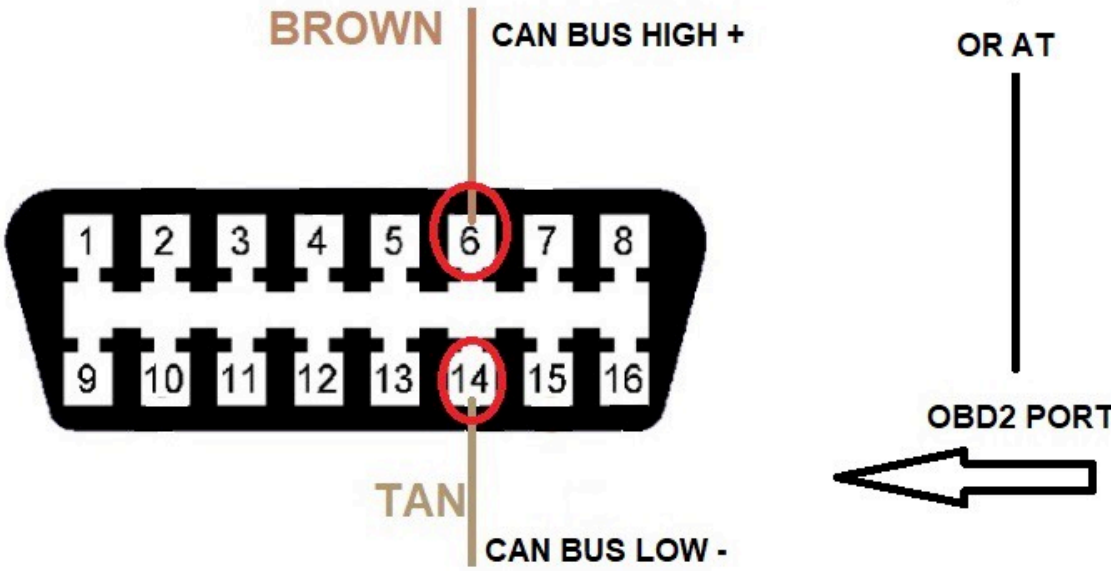
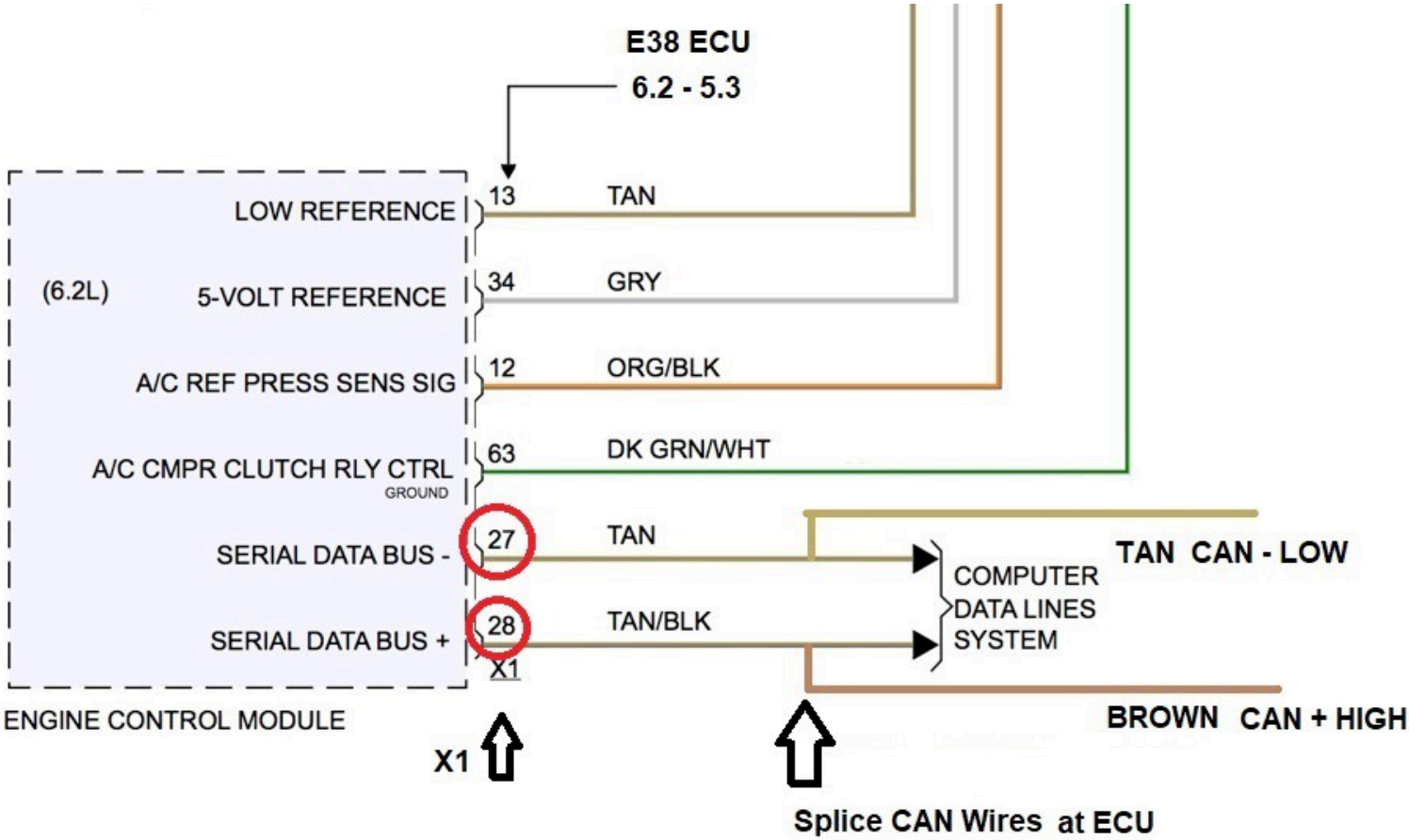

GM E38 ECU

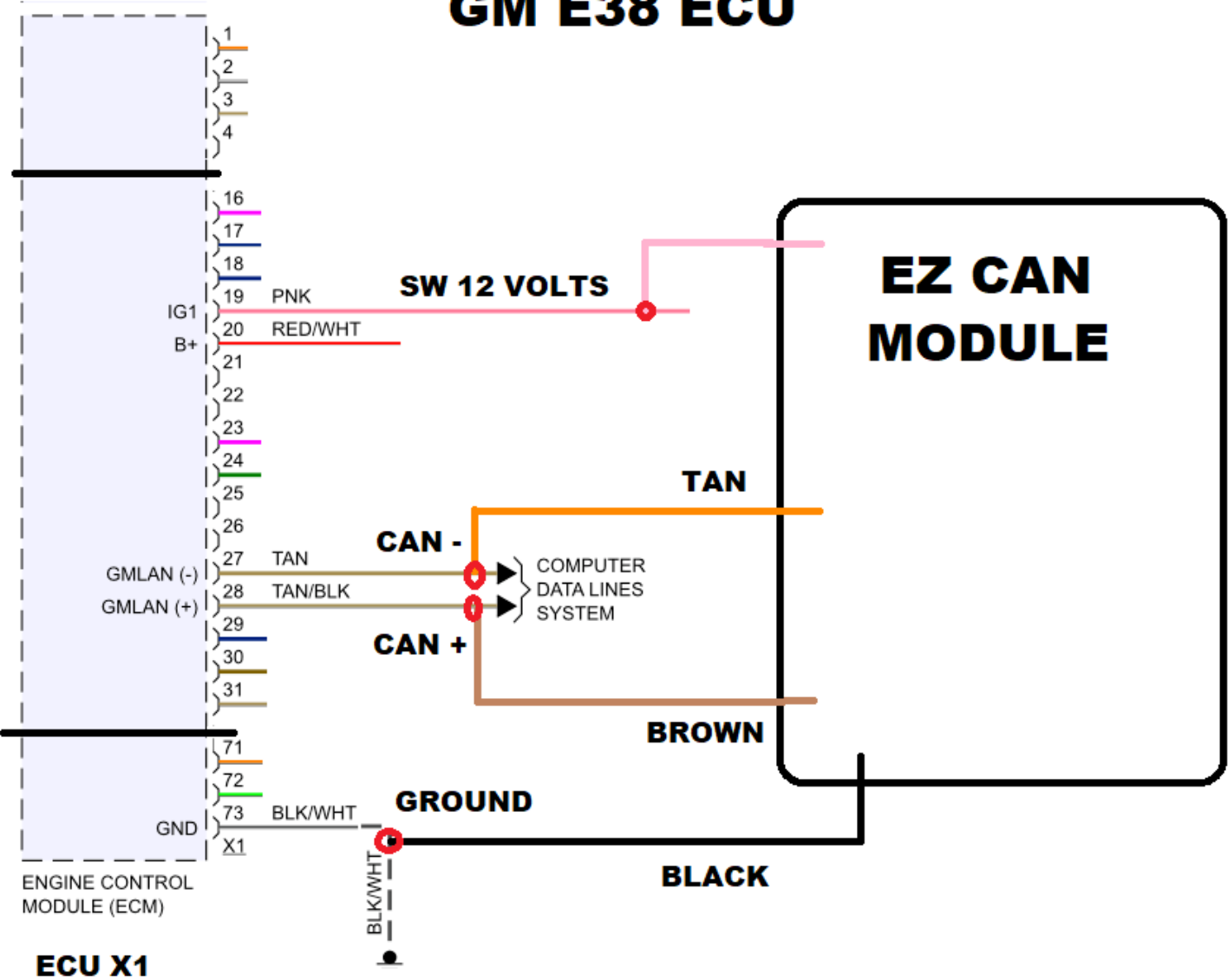

E38 X1 VIEW FROM REAR

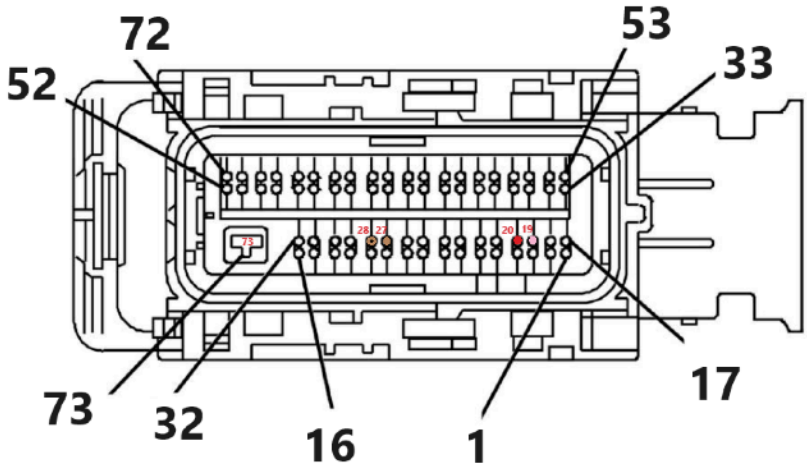

Typical Reverse lamp relay wiring:

We recommend running the reverse lamps off of a separate relay. This moves the load to the relay and not on our module. This will isolate the module and protect it in case the reverse lamps draw too much current or short out.

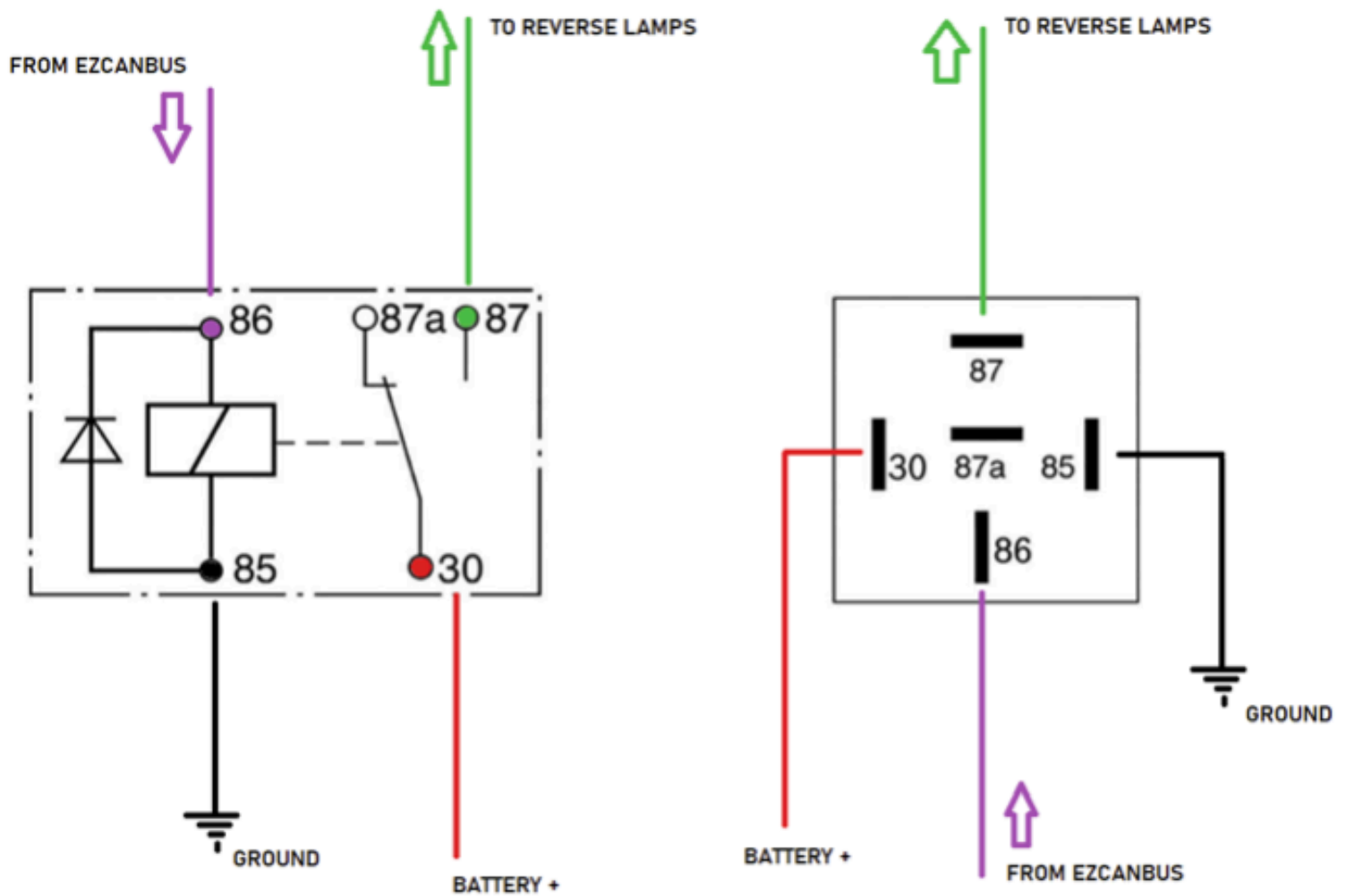

REVERSE LAMP RELAY WIRING